

FACTS | FIGURES | DATA

Flow meter M 123

M 123



Flow meter M123

Measuring ranges 1.5 - 1,000 l/h



M123 PVDF

M123 PSU

M123 PVC

FUNCTION

The M123 flow meter works on the float principle and is used to measure the flow rate in closed pipelines. The medium flows through the vertically installed flow meter from bottom to top. This raises the float and shows the current flow rate on the scale on the measuring device. The read-off edge corresponds to the largest diameter of the float.

The M123 flow meters have a water scale and 2 setpoint indicators as standard.

SPECIAL FEATURES

- Fracture-proof and corrosion-resistant
- Radially removable
- Adhesive special scales, for liquid and gaseous media
- Holder for accessories (limit value contacts)
- Measuring tube carries the DN label, and also the measuring range and material
- PVDF floats and stops as standard
- Measuring ranges 1.5-1,000 l/h
- Less space required thanks to short overall length
- Operating pressure PN 10 at 20 °C

MATERIALS

Measuring tube	Float	Insert, top and bottom	O-ring
PVC	PVDF	PVDF	EPDM (standard), FPM (optional)
PSU	PVDF	PVDF	EPDM (standard), FPM (optional)
PVDF	PVDF	PVDF	FPM (standard)

CONNECTION POSSIBILITIES

Socket	Spigot	Plastic female thread	Metal female thread
PVC adhesive socket (standard)	PP fusion socket	PVC	Stainless steel V4A
PP fusion spigot	PVDF fusion spigot	PP	Malleable cast iron
PVDF fusion socket	PE fusion spigot	PVDF	

PRESSURE LOSS

Measuring range l/h	1.5-15	2.5-25	5-50	10-100	8-80	15-150	20-200	15-150	30-300	50-500	100-1,000
Pressure loss mm WS	46.0	46.0	46.0	46.0	44.7	44.7	44.7	82.8	82.8	82.8	82.8
Measuring range l/h	1.5-15	2.5-25	5-50	10-100	8-80	15-150	20-200	15-150	30-300	50-500	100-1,000
Pressure loss mbar	4.6	4.6	4.6	4.6	4.47	4.47	4.47	8.28	8.28	8.28	8.28

Operating pressure: max. PN 10 at 20 °C

MEASURING ACCURACY

Accuracy Class 4 as defined by VDE/DIN 3513 page 2

Flow in %	10	20	30	40	50	60	70	80	90	100
Total measured value error in %	13.00	8.00	6.33	5.50	5.00	4.67	4.43	4.25	4.11	4.00
Total limit value error in %	1.3	1.6	1.9	2.2	2.5	2.9	3.1	3.4	3.7	4.0

FLOAT-TYPE FLOW METER

d	DN	Measuring range H ₂ O	M123
16	10	1.5-15	■ ●
16	10	2.5-25	■ ● ▲
16	10	5-50	■ ● ▲
16	10	10-100	■ ● ▲
20	15	8-80	■ ● ▲
20	15	15-150	■ ● ▲
20	15	20-200	■ ● ▲
32	25	15-150	■ ● ▲
32	25	30-300	■ ● ▲
32	25	50-500	■ ● ▲
32	25	100-1,000	■ ● ▲

Key to symbols: ■ PSU (Polysulphone), ● PVC, ▲ PVDF

TEMPERATURE RANGE

Measuring tube	Screw connection	Max. temp. at 1 bar
PVC-U	PVC-U	0-60 °C
PA	PVC-U	0-60 °C
PSU	PVC-U	0-60 °C
PSU	PVDF	0-90 °C
PVDF	PVDF	0-100 °C

ARTICLE NUMBERS

d	DN	Measuring tube range l/h	PVC		PSU		PVDF	
			Float PVDF Art.-No.	Float PVDF/Magnet Art.-No.	Float PVDF Art.-No.	Float PVDF/Magnet Art.-No.	Float PVDF Art.-No.	Float PVDF/Magnet Art.-No.
16	10	1.5 - 15	17.003.700	17.003.711	17.000.862	17.001.459		
16	10	2.5 - 25	17.003.701	17.003.712	17.000.864	17.001.461	17.003.611	17.003.622
16	10	5 - 50	17.003.702	17.003.713	17.000.866	17.001.463	17.003.612	17.003.623
16	10	10 - 100	17.003.703	17.003.714	17.000.868	17.001.465	17.003.613	17.003.624
20	15	8 - 80	17.003.704	17.003.715	17.000.895	17.001.467	17.003.614	17.003.625
20	15	15 - 150	17.003.705	17.003.716	17.000.897	17.001.469	17.003.615	17.003.626
20	15	20 - 200	17.003.706	17.003.717	17.000.899	17.001.471	17.003.616	17.003.627
32	25	15 - 150	17.003.707	17.003.718	17.000.901	17.001.473	17.003.617	17.003.628
32	25	30 - 300	17.003.708	17.003.719	17.000.903	17.001.475	17.003.618	17.003.629
32	25	50 - 500	17.003.709	17.003.720	17.000.905	17.001.477	17.003.619	17.003.630
32	25	100 - 1,000	17.003.710	17.003.721	17.000.907	17.001.479	17.003.620	17.003.631

INDIVIDUAL PARTS

Pos.	Designation	Material
1	Measuring tube	PSU, PVC, PVDF
2	Float	PVDF
3	Insert, top	PVDF
4	Union cut	PVC, PP, PVDF
5	Insertion part	PVC, PP, PVDF
6	O-ring	EPDM, FPM
7	Setpoint indicator	PS

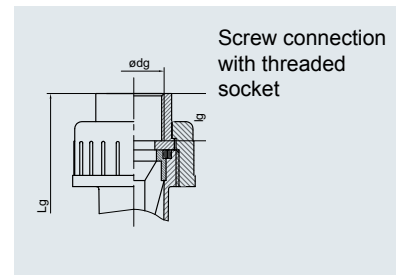
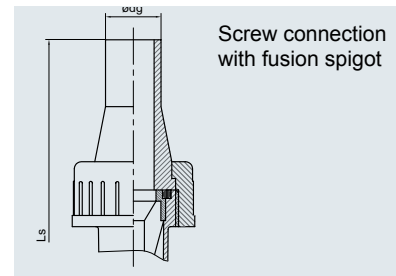
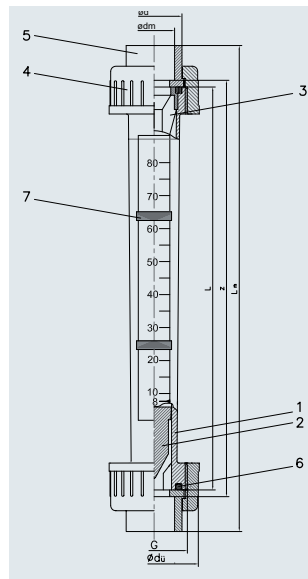

DIMENSIONS (in mm)

Measuring range l/hH ₂ O	Adhesive socket						Fusion socket			Spigot PP			Threaded socket					
	d	DN	G	d _u	L	L _m	d _m	z	L _m	d	L _s	S	d	L _s	l _s			
1.5-15	16	10	3/4"	35	165	199	16	171	199	15.5	175	201		3/8"	199	11		
2.5-25																		
5-50																		
10-100																		
8-80	20	15	1"	20	191	223	20	191	223	19.5	195	223	20	293	1.9	1/2"	223	13
15-150																		
20-200																		
15-150	32	25	1 1/2"	60	200	250	36	206	250	31.5	210	246	32	320	3.0	1"	250	17
30-300																		
50-500																		
100-1,000																		

SPECIAL SCALES

Measuring range	Air 0 bar		Air 1 bar		Air 2 bar		Air 3 bar	
H ₂ O l/h	Art.-No.	N m ³ /h	Art.-No.	N m ³ /h	Art.-No.	N m ³ /h	Art.-No.	N m ³ /h
1.5 - 15	00.000.998	0.10 - 0.55	00.001.050	0.15 - 0.80	00.001.051	0.17 - 0.9	00.001.052	0.20 - 1.1
2.5 - 25	00.001.059	0.2 - 0.95	00.001.060	0.25 - 1.3	00.001.061	0.3 - 1.6	00.001.062	0.4 - 1.9
5 - 50	00.001.070	0.5 - 1.9	00.001.071	0.7 - 2.7	00.001.072	0.8 - 3.4	00.001.073	1.0 - 3.8
10 - 100	00.001.081	0.8 - 3.0	00.001.082	1.0 - 4.2	00.001.083	1.2 - 5.4	00.001.084	1.4 - 6.4
8 - 80	00.001.092	0.6 - 2.8	00.001.093	0.8 - 4	00.001.094	1.0 - 5.0	00.001.095	1.2 - 5.6
15 - 150	00.001.103	1.4 - 5.6	00.001.104	2 - 8	00.001.105	2 - 10	00.001.106	3 - 12
20 - 200	00.001.114	1.5 - 7.0	00.001.115	2 - 10	00.001.116	3 - 13	00.001.117	3 - 15
15 - 150	00.001.125	1.0 - 6.5	00.001.126	1 - 90	00.001.127	1.5 - 11	00.001.128	2 - 13
30 - 300	00.001.136	1.5 - 11	00.001.137	2 - 15	00.001.138	2.5 - 18	00.001.139	3 - 22
50 - 500	00.001.147	3 - 18	00.001.148	4 - 25	00.001.149	5 - 30	00.001.150	5 - 35
100 - 1,000	00.001.158	6 - 30	00.001.159	8 - 44	00.001.160	10 - 54	00.001.161	12 - 62

Measuring range	Air 4 bar		Air 5 bar		Air 6 bar		Air 7 bar	
H ₂ O l/h	Art.-No.	N m ³ /h	Art.-No.	N m ³ /h	Art.-No.	N m ³ /h	Art.-No.	N m ³ /h
1.5 - 15	00.001.053	0.25 - 1.20	00.001.054	0.25 - 1.3	00.000.999	0.26 - 1.45	00.001.055	0.30 - 1.5
2.5 - 25	00.001.063	0.4 - 2.1	00.001.064	0.5 - 2.4	00.001.065	0.5 - 2.5	00.001.066	0.5 - 2.7
5 - 50	00.001.074	1.2 - 4.2	00.001.075	1.2 - 4.6	00.001.076	1.2 - 5.0	00.001.077	1.4 - 5.4
10 - 100	00.001.085	1.6 - 7.0	00.001.086	1.6 - 7.4	00.001.087	2.0 - 8.0	00.001.088	2 - 8.8
8 - 80	00.001.096	1.4 - 6.4	00.001.097	1.4 - 7.0	00.001.098	1.5 - 7.5	00.001.099	1.5 - 8.0
15 - 150	00.001.107	3 - 13	00.001.108	3 - 14	00.001.109	3.5 - 15	00.001.110	3.5 - 16.5
20 - 200	00.001.118	4 - 17	00.001.119	4 - 18	00.001.120	4 - 20	00.001.121	5 - 21
15 - 150	00.001.129	2 - 14.5	00.001.130	2 - 16	00.001.131	2 - 17	00.001.132	2.5 - 18
30 - 300	00.001.140	3 - 24	00.001.141	4 - 26	00.001.142	4 - 28	00.001.143	4 - 30
50 - 500	00.001.151	6 - 40	00.001.152	6 - 44	00.001.153	8 - 48	00.001.154	8 - 50
100 - 1,000	00.001.162	12 - 70	00.001.163	15 - 75	00.001.164	15 - 80	00.001.165	15 - 85

Measuring range	Air 8 bar		Air 9 bar		Air 10 bar	
H ₂ O l/h	Art.-No.	N m ³ /h	Art.-No.	N m ³ /h	Art.-No.	N m ³ /h
1.5 - 15	00.001.056	0.3 - 1.6	00.001.057	0.3 - 1.7	00.001.058	0.35 - 1.8
2.5 - 25	00.001.067	0.6 - 2.9	00.001.068	0.6 - 3.0	00.001.069	0.6 - 3.2
5 - 50	00.001.078	1.4 - 5.8	00.001.079	1.6 - 6.0	00.001.080	1.6 - 6.4
10 - 100	00.001.089	2.0 - 9.0	00.001.090	2 - 10	00.001.091	2 - 10
8 - 80	00.001.100	1.5 - 8.5	00.001.101	2.0 - 9.0	00.001.102	2.0 - 9.5
15 - 150	00.001.111	4 - 17	00.001.112	4 - 18	00.001.113	4 - 19
20 - 200	00.001.122	5 - 23	00.001.123	5 - 23	00.001.124	5 - 25
15 - 150	00.001.133	2.5 - 19.5	00.001.134	3 - 20	00.001.135	3 - 21
30 - 300	00.001.144	4 - 33	00.001.145	5 - 34	00.001.146	5 - 35
50 - 500	00.001.155	8 - 54	00.001.156	8 - 56	00.001.157	10 - 60
100 - 1,000	00.001.166	20 - 90	00.001.167	20 - 95	00.001.168	20 - 100

SPECIAL SCALES

Measuring range	HCl 30-33 % (PSU)		NaOH 30 %		NaOH 50 %	
	Art.-No.	l/h	Art.-No.	l/h	Art.-No.	l/h
H ₂ O l/h						
1.5 - 15	00.005.117	1 - 10	00.005.144	0.1 - 2.0	–	–
2.5 - 25	00.005.118	2.5 - 20	00.005.145	0.2 - 5	–	–
5 - 50	00.005.119	5 - 40	00.005.128	1 - 14	–	–
10 - 100	00.005.120	10 - 85	00.005.129	3 - 35	–	–
8 - 80	00.005.121	8 - 70	00.005.130	2 - 23	00.005.137	0.2 - 3.5
15 - 150	00.005.122	15 - 125	00.005.131	3 - 55	00.005.138	0.5 - 10
20 - 200	00.005.123	20 - 170	00.005.132	5 - 80	00.005.139	0.5 - 16
15 - 150	00.005.124	5 - 125	00.005.133	3 - 55	00.005.140	0.5 - 11
30 - 300	00.005.125	30 - 260	00.005.134	6 - 130	00.005.141	1 - 33
50 - 500	00.005.126	50 - 425	00.005.135	10 - 250	00.005.142	2 - 80
100 - 1,000	00.005.127	100 - 850	00.005.136	40 - 600	00.005.143	10 - 220

Special scales as requested by the customer

Details required: Medium, spec. weight in g/cm³, viscosity in cP or mPas, operating temperature in °C, desired measuring range in l/h.

Application instructions for special scales

When applying special scales later, ensure that the marking ◀ on the scale corresponds with the one on the measuring tube.

ACCESSORIES

Limit value contact Z 40 min.
Limit value contact Z 42 max.

INSTALLATION AND ASSEMBLY INSTRUCTIONS

- Install the flow meter into the pipeline system vertically and without tension.
- Provide an inlet and outlet section
Inlet approx. 10 x DN, outlet approx. 5 x DN.

NOTES ON OPERATION

- Avoid pressure surges, as these can damage the unit.
- Exercise caution when installing. The measuring tube must not come into contact with solvent.
- Before start-up, make sure that the connected parts are sufficiently tightened.
- The union nuts must not be mixed up on a measuring tube made from the material PVDF. The overall length also does not correspond to the dimensions table.

We reserve the right to make technical changes in the interest of improvement.

SPECIAL SCALES H₂O WITH OTHER UNITS OF MEASUREMENT

Measuring range Series M123

d	DN	l/h	Art.-No.	USGPM
16	10	1.5 - 15	00.000.959	0.006 - 0.066
16	10	2.5 - 25	00.000.961	0.01 - 0.11
16	10	5 - 50	00.000.962	0.02 - 0.22
16	10	10 - 100	00.000.963	0.04 - 0.44
20	15	8 - 80	00.000.964	0.035 - 0.35
20	15	15 - 150	00.000.965	0.06 - 0.66
20	15	20 - 200	00.000.966	0.08 - 0.8
32	25	15 - 150	00.000.967	0.06 - 0.66
32	25	30 - 300	00.000.968	0.13 - 1.3
32	25	50 - 500	00.000.969	0.22 - 2.2
32	25	100 - 1,000	00.000.970	0.44 - 4.4

PRESSURE CORE TABLE FOR GASES: CALIBRATION PRESSURE 0 BAR

Operating pressure in bar	Factor x display value	Operating pressure in bar	Factor x display value
0.0	1.000	3.0	2.000
0.2	1.095	4.0	2.240
0.4	1.184	5.0	2.450
0.6	1.265	6.0	2.650
0.8	1.340	7.0	2.830
1.0	1.414	8.0	3.000
1.5	1.580	9.0	3.165
2.0	1.730	10.0	3.320

Limit value contact Z 40 min./Z 42 max.

For float-type flow meters

M335/M350/M123/ M23 PVDF



USE

The limit value contacts Z40 and Z42 are used for external monitoring of limited flow values on our (float-type) flow meters. They are pushed onto the guide rod located on the flow meter and can be adjusted to any desired value on the corresponding scale.

FUNCTION

A solenoid installed in the float closes or opens a reed contact permanently cast in the limit value contact. The switching function is bistable. This means that the switching state is maintained even if the solenoid float moves away from the contact.

SWITCHING STATES

	Float above	Float below
Z40 min	open	closed
Z42 max	closed	open

Attention

When retrofitting the flow meter with limit value contacts, ensure that the standard float is replaced with a solenoid float. The solenoid float is clearly identified by an “M” on the top.

ORDER NUMBERS

Z40 min. 17.100.686

Z42 max. 17.100.687

TECHNICAL DATA

Switching voltage*	max. 230 V~
Switching rating*	max. 10 W/12 VA
Switching current*	max. 0.5 A
Contact resistance	< 200 mOhm
Leakage resistance	> 10 ¹¹ Ohm
Permissible ambient temperature	0 to +55°C
Protection type	in ace. with DIN 40050-IP 65
Switching hysteresis	1-2 mm float travel

We reserve the right to make technical changes in the interest of improvement.

* Even a brief overshoot is not permitted. This is uncontrollable with inductive or capacitive peaks, e.g. with contactors or solenoid valves. It is therefore recommended to use a limit value switch or a contact protection relay.

M 123

