

DU06

Ultrasonic- Flowmeter and Counter with Local Indication

- heavy duty meter, brass- and stainless steel version
- for 1/2" and 2" pipes
- very broad measurement range: 0,5...80 and 8...1000 l/min
- 2-line LCD-display for flow and total indication
- output signals: 4...20 mA, 0...10 V for flow, pulses for flow quantity, totaliser
- P_{max} : 25 bar, T_{max} : 100 °C



Description:

The DU06 flowmeter is fitted with two ultrasonic sensors that are facing each other. The echo travel time is a function of the flow rate. The sensors act alternately as transmitter and receiver.

The echo time difference is proportional to the flow rate. In contrast to other types of ultrasonic flowmeters, the sensors are oriented parallel to the flow stream. This results in an extremely compact meter which is highly accurate, has outstanding turndown ratio dynamics and can monitor and meter very high flow rates without any reduction in pipe cross-sectional area.

Typical applications:

The DU06 measures, monitors and totalizes liquid flow. Among the applications for this device are cooling systems (water / glycol mixtures), non-conductive products (demineralized water, low viscous oils) and chemically aggressive and caustic liquids.

Models:

DU06.M... brass version, housing made of brass 2.0401, sensors made of stainless steel 1.4571, FKM gaskets, (EPDM optional), for 1/2" pipe only

DU06.E... stainless steel version, housing made of stainless steel 1.4571, sensors made of stainless steel 1.4571, FKM gaskets, (EPDM optional), for 1/2" to 2" pipe

Measuring ranges:

Measuring range *)	Brass-version	St. steel-version	Process-connection
0,5...80 l/min	DU06.M...R015	DU06.E...R015	R 1/2 male
8...1000 l/min	-	DU06.E...R050	R 2 male

*) Maximum ranges are specified. For a higher resolution the output can be programmed for end values < max. measuring range

Technical Data:

Measurement function: flow speed, flow quantity, totaliser

Measuring principal: ultrasonic transit-time difference method

Medium: acoustically conductive liquids, gas solids contents < 10 vol.%

Flow direction: adjustable in device

Mounting position: any, rotatable housing

Max. pressure: 25 bar

Medium temperature: -20...+100 °C

Ambient temperature: -10...+60 °C

Accuracy: ± 2% of full scale

Response time: 0,8...8 s, factory setting ca. 1,6 s

Display: LCD, 2 x 16 digit, illuminated

Units: selectable

Protection class: IP67

Dimensions:

DU06...R015, 1/2"

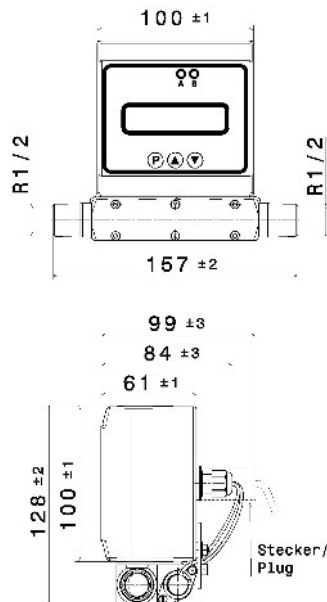

Order Code:

Order number: DU06. E. V. R025. 0. 0

Ultrasonic flowmeter and counter with local indication

Material version:

M = brass housing, sensors st. steel (with R 1/2 male connection only)
E = st. steel housing, sensors st. steel
S = special version

Gaskets:

V = FKM (standard)
E = EPDM
S = special gasket

Measuring range / Process connection:

R015 = 0,5...80 l/min, R 1/2 male
R050 = 8...1000 l/min, R 2 male (only DU06.E...)

Output signal:

0 = universal output for power, voltage or frequency, adjustable on site and 2 limit relays

Options:

0 = without
9 = please specify in plain text

Accessory:

DP06-Z.SK: RS232 Interface cable

Electrical Data:

Power supply: 24 V_{DC} ± 15%

Power consumption: 200 mA max.

Outputs: 4...20 mA, 0...10 V, frequency output (programmable, max. 32 kHz), R_i = 2 kOhm

Limit value relay: 2 x changeover cont., 30 V_{DC} / 1 A

Interface: RS232, RS-485

DU06...R050, 2"

