

CONTACT PRESSURE GAUGE WITH DIAPHRAGM

Chemical execution
Thread or DIN flange

Nominal size 100 and 160

Accuracy class 1,6 and 2,5

DIN EN 837-3

For tough requirements such as for use in industrial production plants. For highly viscous and crystallizing substances, open connection flanges are used, which enable easy cleaning.

Limit signal transmitters open or close electrical circuits depending on the pointer position of the pressure measuring device.



DRUCK & TEMPERATUR



Type	4312	4412	4512	4612	Options
Nominal size	100		160		
Symbol					
Silicone oil filling	without filling	with filling	without filling	with filling	
Type of contact	Magnetic snap-action contact or inductive contact				
Accuracy	Class 1,6 Class 2,5 with liquid filling and measuring ranges < 600 mbar				Class 1,0 or 0,6
Ranges	0...10 up to 0...400 mbar (flange diameter 160, opt. 400 mbar flange Ø100) 0...0,6 up to 0...40 bar (flange diameter 100) -0,6...0 up to -1...+15 bar (flange diameter 100)				other graduations and other units
Applications	Constant load: full scale value Alternating load: 0,9 x full scale value Overload, short time: 1,3 x full scale value				higher overpressure safety
Case	CrNi-steel				Safety housing
Bayonet ring	CrNi-steel				
Measuring element	CrNi-steel				
Connection	CrNi-steel				
Thread, flange	G1/2 B, bottom or DIN-flange (see tables at next pages), PN40				others on request, Channel drilling Ø10mm
Wetted parts	CrNi-steel, sealing FPM (Viton)				PTFE coating, Tantal, Silver
Window	Polycarbonate				Safety glass
Movement	CrNi-steel				
Dial	Aluminium white, scale and lettering black				
Pointer	Aluminium black				
Protection DIN EN 60 529/IEC 529	IP54	IP65	IP54	IP65	
Temperatures	Medium: -20°C up to 100°C, ambient: -25°C up to 60°C				

Type 4312, 4412, 4512, 4612

Dimensional drawing

Dimensions in mm



DRUCK & TEMPERATUR

Type 4312, 4412, 4512, 4612 with thread

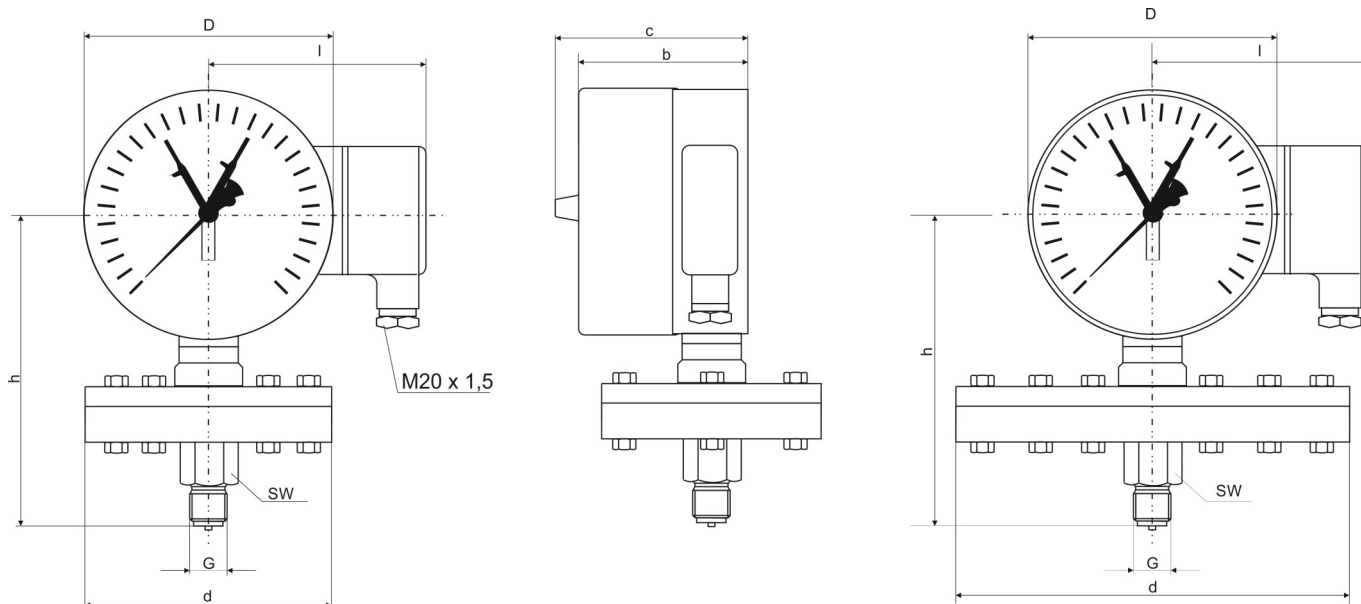

Dimensions - flange 100 mm (from 600 mbar)

Type	NS	D	b	d	c	h	I	SW	G	Weight approx.
4312	100	101	78	100	88	115	88	22	G 1/2 B	1,6 kg
4512	160	160	97	100	107	145	120	22	G 1/2 B	2,2 kg
4412	100	101	78	100	88	115	88	22	G 1/2 B	1,6 kg
4612	160	160	97	100	107	145	120	22	G 1/2 B	2,2 kg

Dimensions - flange 160 mm (up to 400 mbar)

Type	NG	D	b	d	c	h	I	SW	G	Weight approx.
4312	100	101	78	160	88	115	88	22	G 1/2 B	2,6 kg
4512	160	160	97	160	107	145	120	22	G 1/2 B	3,2 kg
4412	100	101	78	160	88	115	88	22	G 1/2 B	2,6 kg
4612	160	160	97	160	107	145	120	22	G 1/2 B	3,2 kg

Deviating dimensions are possible!

Type 4312, 4412, 4512, 4612

Dimensional drawings

Dimensions in mm



DRUCK & TEMPERATUR

Type 4312, 4412, 4512, 4612 with flange

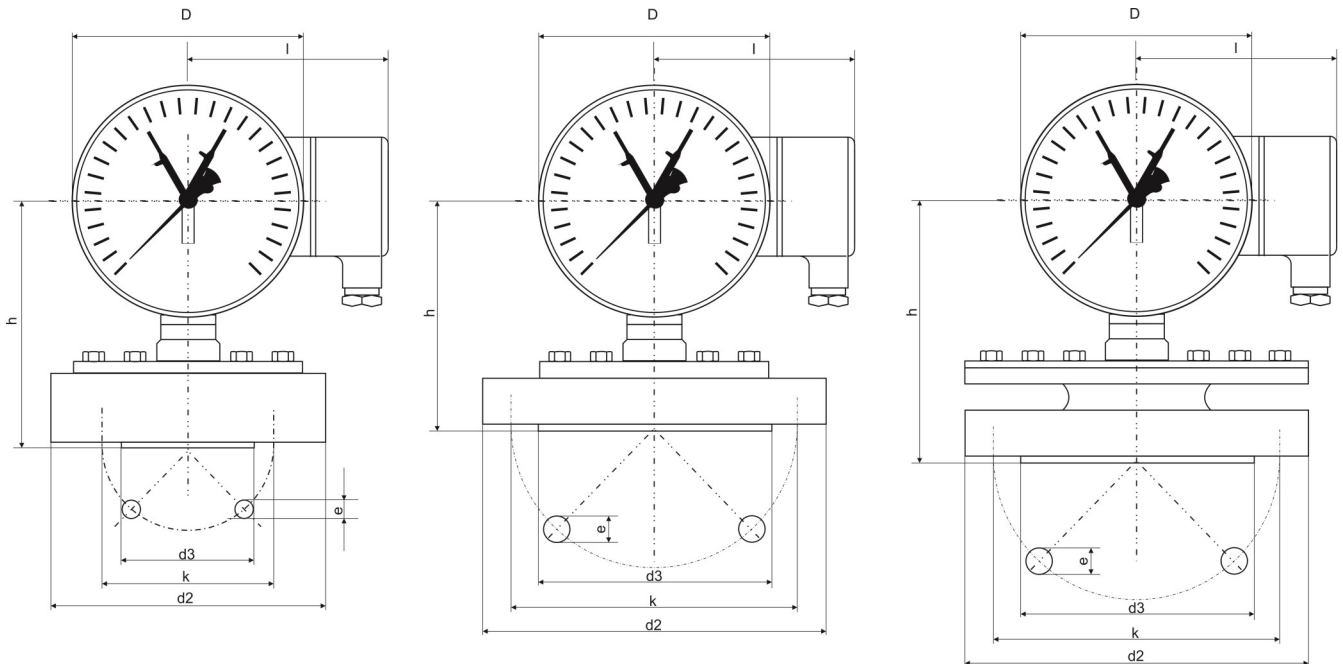

Dimensions - flange 100 mm (from 600 mbar)

DIN flange	d2	d3	h - NS 100	h - NS 160	k	e	I - NS 100	I - NS 160
DN 15	100	45	100	130	65	4 x M12	88	120
DN 20	105	58	100	130	75	4 x M12	88	120
DN 25	115	68	100	130	85	4 x M12	88	120
DN 40	150	88	92	125	110	4 x Ø18	88	120
DN 50	165	102	92	125	125	4 x Ø18	88	120
DN 65	185	122	92	125	145	8 x Ø18	88	120
DN 80	200	138	92	125	160	8 x Ø18	88	120

Dimensions - flange 160 mm (up to 400 mbar)

DIN flange	d2	d3	h - NG 100	h - NG 160	k	e	I - NG 100	I - NG 160
DN 15	100	45	120	150	65	4 x M12	88	120
DN 20	105	58	120	150	75	4 x M12	88	120
DN 25	115	68	120	150	85	4 x M12	88	120
DN 40	150	88	120	150	110	4 x Ø18	88	120
DN 50	165	102	120	150	125	4 x Ø18	88	120
DN 65	185	122	92	125	145	8 x Ø18	88	120
DN 80	200	138	92	125	160	8 x Ø18	88	120

Deviating dimensions are possible!

Type 4312, 4412, 4512, 4612

Magnetic snap-action contact

Application

Magnetic snap contacts can be used in different operating conditions.

Contact protection relays are recommended for high or low switching capacities.

Electronic contacts are used in liquid-filled measuring devices to avoid incorrect switching.





Attention: Only inductive contacts with ATEX approval may be used in potentially explosive areas.

With nominal operating voltages > 50 VAC or > 120 VDC, the contacts must be reliably earthed according to DIN VDE 0110.

Technical data

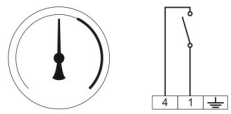
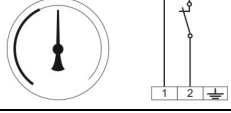
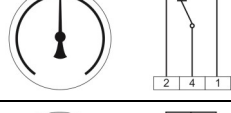
Switching voltage:	max. 250 V
Min. switching voltage:	24 V (with ohmic load and operation in air)
Switching current:	max. 1,0 A
Continuous current:	max. 0,6 A
Minimum current:	20 mA
Switching power:	max. 30 W; 50 VA
Minimum switching power:	0,4 W; 0,4 VA
Contact material:	Ag80 Ni20
Switching accuracy:	ca. 2-5% full of scale value

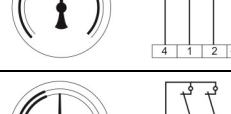
Switching function

Type	clockwise under increasing pressure	Cable socket connection diagram
M-1	Contact closes	
M-2	Contact opens	
M-3	1-fold changeover contact (1 set point)	
M-11	Contact 1 closes Contact 2 closes	
M-12	Contact 1 closes Contact 2 opens	
M-21	Contact 1 opens Contact 2 closes	
M-22	Contact 1 opens Contact 2 opens	
M-33	2-fold changeover contact (2 set points)	

Modifications reserved!

Type 4312, 4412, 4512, 4612

Inductive contact



DRUCK & TEMPERATUR

Application

Inductive contact in pointer-type measuring instruments are equipped with electrical distance sensors (proximity sensors) in accordance with DIN 19234 resp.

When using the Ex isolating switch amplifier, the equipment corresponds to type of ignition property "I". It is approved under the classification EEx ib II C T6 for use in potentially explosive areas (zone 1 and 2).

Multi-function relays are recommended for installation in normal industrial plants for which explosion protection is not required.

Technical data

Nominal voltage: 8V = (Ri = 1 k OHM)
 Operating voltage: 5...25 V
 Current consumption: approx. 1...3 mA
 Switching accuracy: approx 0,5% of full scale value
 Ambient temperature: -20°C...+70°

Switching function

Type	clockwise under increasing pressure	Cable socket connection diagram
I-1	Contact closes	
I-2	Contact opens	
I-11	Contact 1 closes Contact 2 closes	
I-12	Contact 1 closes Contact 2 opens	
I-21	Contact 1 opens Contact 2 closes	
I-22	Contact 1 opens Contact 2 opens	

Modification reserved!